

DK-M3-RS-U2-2M-20-L

Developer's Kit

Two-Axis Two-Mirror Beam Steering System

Miniature piezo smart stages with built-in controllers enable simple, precise point-to-point beam steering

- Piezo stages with continuous 360° rotary motion
- Mounted mirrors, laser and two-axis base
- Each rotary stage only 11.75 x 21.9 x 16 mm
- Closed-loop controller embedded in each stage
 - *No separate electronics needed*
 - 3.3 VDC input
 - Direct digital input of motion commands (I²C, SPI, or UART)
- Angular resolution ~21.9727 mdeg closed loop
 - Built-in absolute position sensor
- Millisecond step and settle times
 - 0.5 deg in 16 ms closed loop
 - 0.5 deg in 1.2 ms open loop
- Holds position with zero power and no jitter

Two-axis beam steering on your fingertip

The DK-M3-RS-U2-2M-20-L is a complete piezoelectric beam steering system with a familiar galvo form factor, but a drastically smaller size: **only 11.75 mm long x 21.9 mm wide x 16 mm tall including the embedded closed-loop controller.**

The mounted aluminum-coated mirror moves at up to 1,100 deg per second with repeatability of +/-0.05 deg for precise, point-to-point beam steering.

Embedded controller means tiny size plus fast, easy integration

Patented piezoelectric motors along with position sensors, bearings, drive electronics and embedded firmware are all integrated inside each of the two miniature rotary stages.

We've eliminated the extra bulk of a separate external controller.

Along with smallest system size, this makes for fast, easy integration into your system. The beam steering system accepts direct input of high-level digital commands from your system processor or use the USB adapter to power and control the system from a PC. Input is only 3.3 VDC.

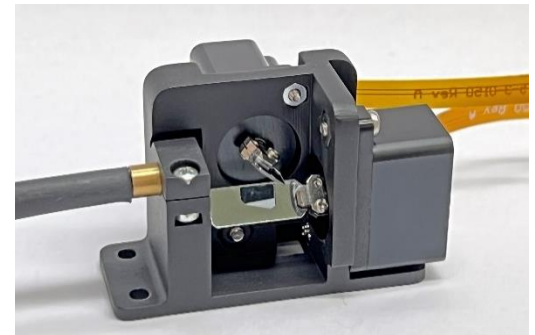

APPLICATIONS

This system is ideal for precise, point-to-point beam steering in a limited space, with dynamic positioning up to 100 Hz. The 3.3 VDC input makes it suited for handheld/portable instruments.

Medical

- Dermatology lasers, fluorescence microscopes and imaging instruments
- Next-generation sequencing (NGS)

Industrial

- Quantum computing
- Laser marking, engraving, machining
- 3D printers
- Remote sensing e.g., pollution sources
- LIDAR, 3D measurement, spectroscopy

Telecommunications

- Free-space optical communication
- Variable optical attenuation
- Fiber-to-fiber optical switching

Aerospace and Defense

- Target designation, jitter compensation
- Automated obstacle detection, tracking and avoidance for robots, UAVs, etc.

Rotating shaft for
each mirror

Closed-loop
controller inside

Input 3.3VDC and
high-level motion commands

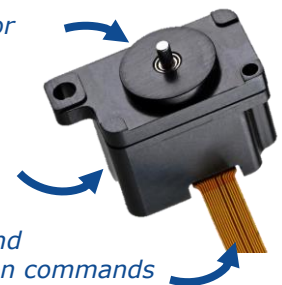

Each Developer's Kit contains two
M3-RS-U2 Rotary Smart Stages

Preliminary Product Datasheet

The Developer's Kit

The DK-M3-RS-U2-2M-20-L Beam Steering System Developer's Kit includes two smart stages, mounted mirrors, a 650nm collimated laser, base, demo board, cables, USB adapter and software for system evaluation and development.

Smart Stages with mounted mirrors, laser and base

The standard aluminum-coated mirrors are pre-mounted on the M3-RS-U2 rotary smart stages. The stage's built-in controllers accept direct digital control via the FPC connector.

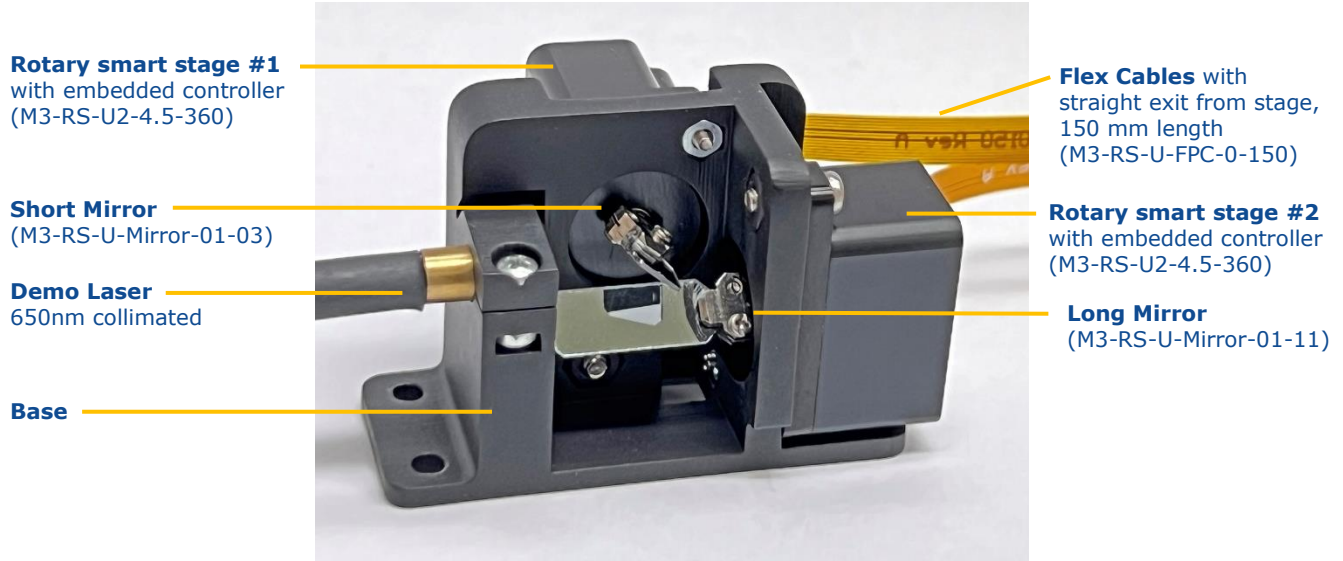

Included accessories

The Developer's Kit accessories include a demo board, cables, tools and software to aid in evaluation and system development. New Scale Pathway™ software for Windows provides an easy-to-use graphical interface to control the systems from a PC screen, or develop your own code using the intuitive scripting tool.

Demo Board

Interface to PC
 Connection to laser power supply
 Direct access to:

- SPI, I²C and UART digital control interfaces
- PWM Position (Output)
- Scope probable access
- ON Target (Output)
- DC Power

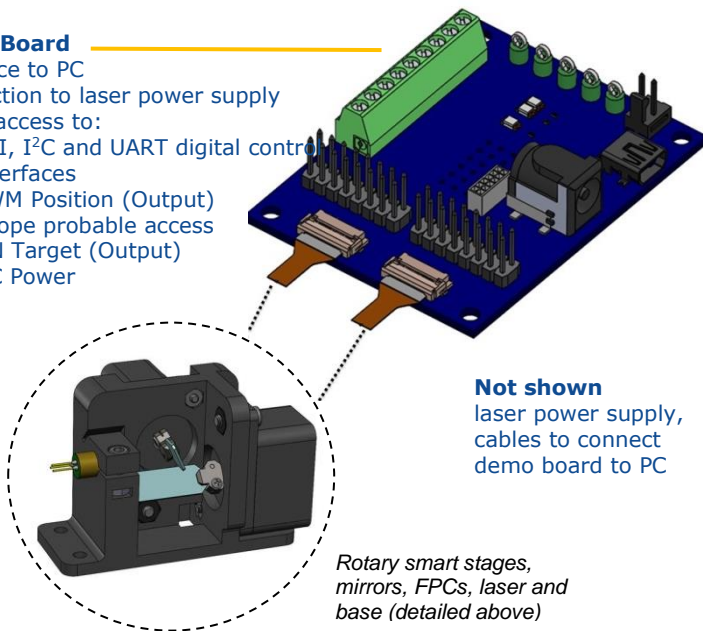

Not shown
 laser power supply,
 cables to connect
 demo board to PC

Rotary smart stages,
 mirrors, FPCs, laser and
 base (detailed above)



New Scale Pathway Software for Windows
 For system evaluation and development

Specifications – DK-M3-RS-U2-2M-20-L Developer's Kit

M3-RS-U2-4.5-360 Rotary Smart Stage	
Rotation Range	360 deg continuous rotation
Speed	> 1,100 deg/sec
Acceleration	> 1,000,000 deg/sec ² *
Stall Torque (minimum)	0.04 N-mm
Holding Torque (minimum)	0.08 N-mm (zero power)
Recommended Maximum Payload mounted to rotating shaft (Payload must be balanced)	
Mass	3 g
Inertia	350 g-mm ²
CLOSED-LOOP performance (with built-in position sensor)	
Recommended Step Frequency	Up to 100 Hz
Absolute Encoder Resolution	~21.9727 mdeg
Repeatability	+/-0.05 deg
Accuracy	0.25 deg
Closed-Loop Step & Settle Times (Typical)*	
0.5 deg	16 ms
5 deg	22 ms
20 deg	31 ms
Open-Loop Step & Settle Times (Typical)*	
0.05 deg	0.5 ms
0.5 deg	1.2 ms
5 deg	5 ms
20 deg	11.2 ms
Input Voltage	3.3 VDC +/- 10%
Power Consumption (typical)	750 mW active, moving 190 mW active, ready 50 mW standby
Stage Mass	4.7 g
Operational Lifetime	>2 million random positions or 7-years, whichever occurs first
Temperature/Relative Humidity	0 to +60 C, non-condensing
Compliance	RoHS; CE pending
Communication Interface	I ² C, SPI, UART Input directly to M3-RS
Controller	Integrated into stage, 64 MIPS NO external controller needed

* With 0.6 g-mm² inertial load mounted to output shaft, based on a target tolerance of 2 encoder counts.

Inertial load of mounted mirror M3-RS-U-Mirror-01-11

Internal Stage Inertia	0.39 g-mm ²
Mirror Clamp	0.45 g-mm ²
Mirror	0.15 g-mm ²
Total Inertia	0.99 g-mm ²

Standard Mounted Mirrors (included in kit)	
Size – Short Mirror	3 x 5 x 0.4 mm
Size – Long Mirror	11 x 5 x 0.4 mm
Material	Float Glass
Coating	Protected Aluminum (MgF2)
Operational Bandwidth	0.350 – 4.0 μm
R _{avg} Reflectivity (0.350 – 4.0 μm)	90%
Maximum Beam Diameter	2 mm
Flatness (632 nm)	λ/4 over any 2 mm length
Surface Quality	60 – 40 scratch/dig
CW Damage Threshold (4 μm)	6 W/cm ²
Pulsed Damage Threshold (1 μsec pulses, 350 nm, 20 Hz)	0.3 J/cm ²

Demo board

The demo board is included in the Developer's Kit to support easy product evaluation. IT IS **NOT** REQUIRED FOR BEAM STEERING OR FINAL INTEGRATION INTO A SYSTEM.

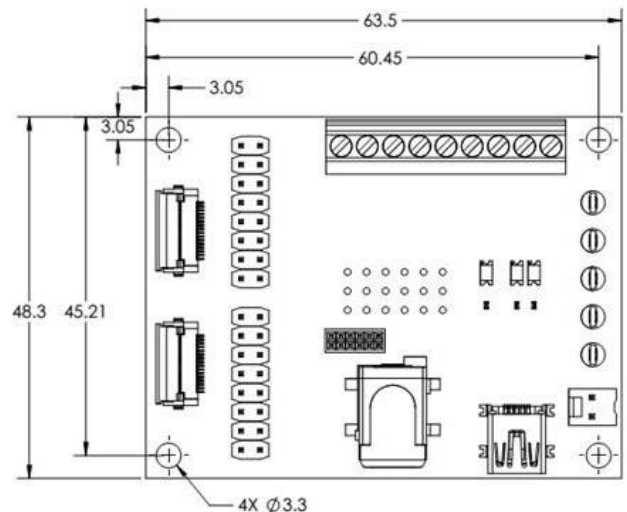
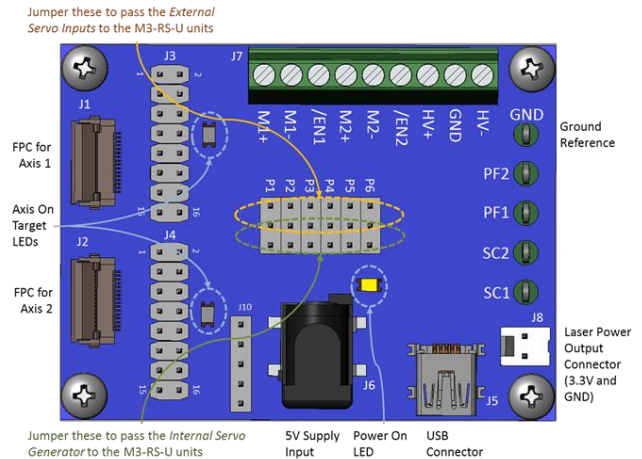

Preliminary Product Datasheet

Drawings

M3-RS-U2-4.5-360 Rotary Stages

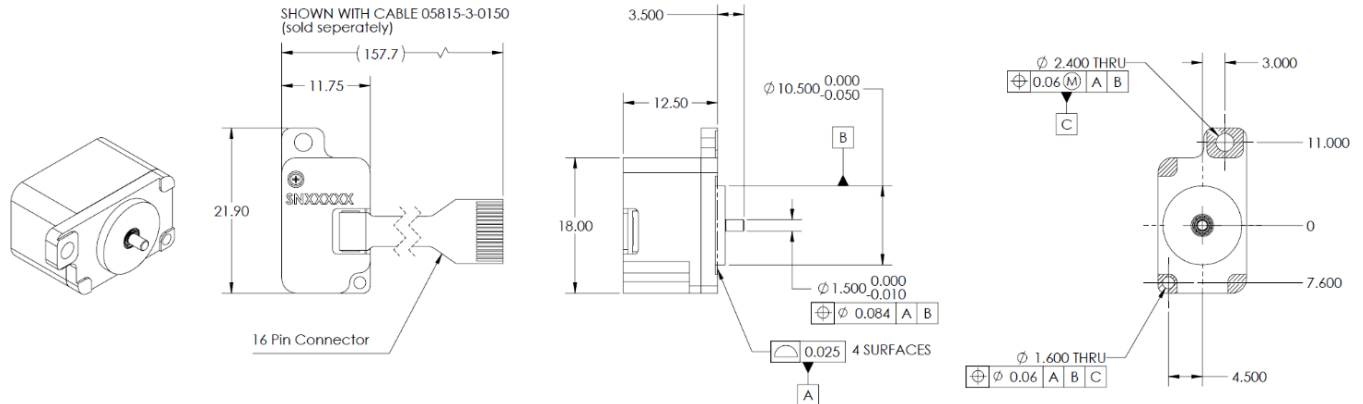

Ordering information

Developer's Kit	Description
DK-M3-RS-U2-2M-20-L	<p>Developer's Kit, Two- Axis Two-Mirror Beam Steering System</p> <ul style="list-style-type: none"> • Two M3-RS-U2-4.5-360 Rotary Smart Stages with embedded controller and straight FPC • One M3-RS-U-Mirror-01-03, mounted to stage • One M3-RS-U-Mirror-01-11, mounted to stage • One 650nm collimated laser • Base • Demo board and cables for testing and PC connection • Power supply • New Scale Pathway™ Software
Optional Components	Description
M3-RS-U2-4.5-360	<p>Rotary Stage Positioning Module Piezo smart stage with built-in controller and M3-RS-U-FPC-0-150 flex cable <i>Two stages are included in the kit.</i></p>
M3-RS-U-Mirror-01-03	<p>Mounted mirror, 3 x 5 x 0.4 mm Inertia 0.50 g-mm² <i>One, 3-mm mirror is included in the kit.</i></p>
M3-RS-U-Mirror-01-11	<p>Mounted mirror, 11 x 5 x 0.4 mm Inertia 0.60 g-mm² <i>One, 11-mm mirror is included in the kit.</i></p>
M3-RS-U-FPC-0-150	<p>FPC cable with straight exit from stage 150 mm length (standard cable, included with stage)</p>

Optional components

Mounted Mirrors

Each kit includes one, 3-mm long mounted mirror and one, 11-mm long mounted mirror pre-attached to the stages.

You may order additional mounted mirrors if desired. Tools to attach the mounted mirrors to the stage are included in the kit.

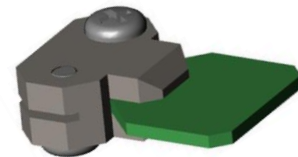

FPC Cables

Each kit includes two flexible printed circuit cables for stage input. You may purchase cables in other lengths, with straight or 90-degree exit angles.

Additional Stages

Each kit includes two rotary stage positioning modules. Additional modules may be ordered separately.

Additional information

Visit the website for CAD files and user manuals (registration required):

<https://www.newscaletech.com/downloads/please-register/>