



# O2E

## OPTICAL TO ELECTRICAL CONVERTER

SPECIFICATION SHEET

AVAILABLE IN PXI

AVAILABLE IN MatriQ

The O2E is a high bandwidth, broadband optical to electrical converter available in a range of configurations.



### Various wavelength ranges

The O2E can be customized to a wide range of wavelengths and is suitable for single mode and multimode applications.



### High bandwidth

Our high performing O2E allows you to successfully test high baudrate signals with up to 50GHz of bandwidth.

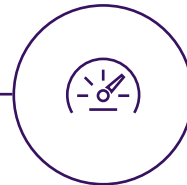

### Calibrated readings

Onboard storage of calibration data can be accessed via SCPI commands, making it easier to generate calibrated measurements and scale your measurement capabilities.



### Amplified RF output

Various conversion gain options allow you to easily measure low power, high speed optical signals

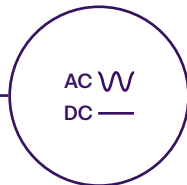

### DC or AC coupled

Choose from DC or AC coupling to suit your specific test application.

- Optical signal eye diagram measurement
- Relative intensity noise (RIN) measurement
- Optical pulse characterization
- Modulation depth measurement
- Extinction ratio measurement
- Precision timing/triggering
- Frequency response measurement of devices

## Simple, intuitive control with COHESIONUI™

COHESIONUI makes it simple to control our PXI or MatriQ instruments from a PC, tablet or smartphone. Its cutting-edge design offers a sleek modern interface, cross device compatibility, customizable views and remote network access.

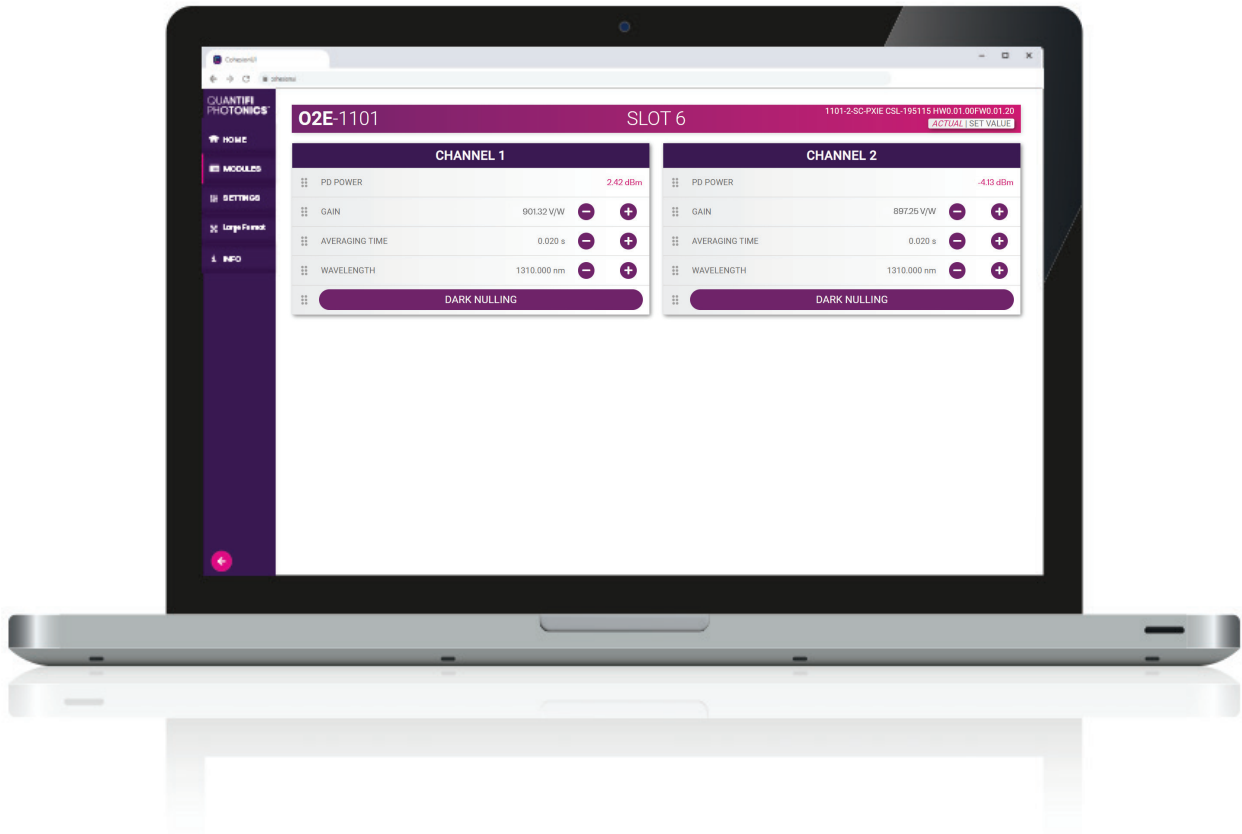

## CHOOSE YOUR FORM FACTOR

### PXIe – MODULAR

Our expanding range of PXIe optical test solutions are used by customers in mixed-signal test and measurement systems, reducing complexity, lowering the cost of test and accelerating time to market.

- Multi vendor, open standard with over 2500 PXI modules available
- Advanced timing and synchronization capabilities across instruments
- Low latency, high performance processing and fast data throughput
- Design and build scalable, high channel count systems
- Small footprint and lower power consumption



### MATRIQ – COMPACT & PORTABLE

The MATRIQ series provides the same high-performance test capabilities of our PXIe modules in an compact benchtop design. MATRIQ instruments are simple to setup and easy to operate, making them the perfect choice for your optical lab or test bench.

- Same performance and control as our PXIe modules
- Plug and play with USB or Ethernet connectivity
- Control via the web-based GUI, COHESIONUI or SCPI commands
- Compact and portable design saves benchtop space



## O2E TECHNICAL SPECIFICATIONS

### PXI - MODULAR

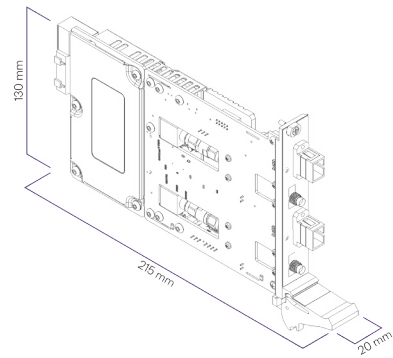

O2E-1001-2-FC-PXIE

### MATRIQ - COMPACT & PORTABLE

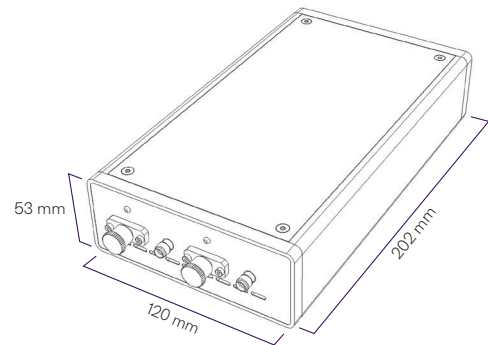

O2E-1001-2-FC-MTRQ

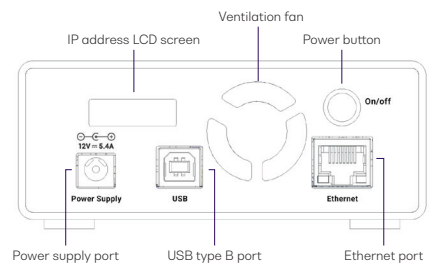

## O2E TECHNICAL SPECIFICATIONS

General Specifications	PXI	MatriQ
Bus connection	PXIe	USB and Ethernet
PXI slots	1	-
Optical connector type	FC/PC, FC/APC, SC/APC, SC/PC	FC/PC, FC/APC, SC/APC, SC/PC
Dimensions (HxWxD)	130 mm x 20 mm x 215 mm   5.1" x 0.8" x 8.5"	45 x 114 x 212 mm   1.7 x 4.5 x 8.3 inch
Weight	~ 1 kg   ~2.2 lbs	~ 1.1 kg   ~ 2.4 lbs
Operating temperature range	5 °C to 45 °C   41 °F to 113 °F	5 °C to 45 °C   41 °F to 113 °F
Storage temperature range	-40 °C to 70 °C   -40 °F to 158 °F	-40 °C to 70 °C   -40 °F to 158 °F

Power Specifications	PXI	MatriQ
AC input voltage range	Please refer to the latest PXI Express Hardware Specifications published by the PXI Systems Alliance.	90 to 264 VAC
AC input current		1.3A (115 Vac), 0.9A (230 Vac)
AC frequency range		47 to 63 Hz
DC output voltage		12 V
DC output current max		5.41 A
Dimensions (LxWxH)		4.58 x 2.06 x 1.23" (116.3 x 52.4 x 31.3 mm)

Model Number	1001	1001
Bandwidth	9.5 GHz (typ), 8.5 GHz (min)	9.5 GHz (typ), 8.5 GHz (min)
Wavelength	750 to 1650 nm	750 to 1650 nm
Number of channels	1 or 2	1 or 2
Calibrated wavelengths (nm)	850, 1310, 1490, 1550	850, 1310, 1490, 1550
RF coupling	DC	DC
RF connector	SMA (3.5 mm)	SMA (3.5 mm)
RF impedance	50 ohms	50 ohms
Fiber	62.5 $\mu$ core MMF	62.5 $\mu$ core MMF
Damage level peak power	+7 dBm	+7 dBm
Optical return loss	30 dB SMF1 16 dB MMF	30 dB SMF1 16 dB MMF
PDL at 1550 nm	-	-
Conversion gain	430 V/W (typ), 375 V/W (min) at 1550 nm 450 V/W (typ), 394 V/W (min) at 1310 nm 250 V/W (typ), 221 V/W (min) at 850 nm	430 V/W (typ), 375 V/W (min) at 1550 nm 450 V/W (typ), 394 V/W (min) at 1310 nm 250 V/W (typ), 221 V/W (min) at 850 nm
Low frequency cutoff	0 Hz	0 Hz
Noise equivalent power <sup>1</sup>	15 pW/sqrt(Hz) (typ)	15 pW/sqrt(Hz) (typ)
Average power reading	Yes	Yes

Model Number	1101 <sup>2</sup>	1101 <sup>2</sup>
Bandwidth	25 GHz (typ), 24 GHz (min)	25 GHz (typ), 24 GHz (min)
Wavelength	950 to 1650 nm	950 to 1650 nm
Number of channels	1 or 2	1 or 2
Calibrated wavelengths (nm)	1310, 1490, 1550	1310, 1490, 1550
RF coupling	AC	AC
RF connector	K (2.92 mm)	K (2.92 mm)
RF impedance	50 ohms	50 ohms
Fiber	SMF-28	SMF-28
Damage level peak power	+4 dBm	+4 dBm
Optical return loss	30 dB SMF1	30 dB SMF1
PDL at 1550 nm	0.25 dB (max)	0.25 dB (max)
Conversion gain	900 V/W (typ), 700 V/W (min) at 1550 nm	900 V/W (typ), 700 V/W (min) at 1550 nm
Low frequency cutoff	< 100 KHz	< 100 KHz
Noise equivalent power <sup>1</sup>	39.7 pW/sqrt(Hz) (typ)	39.7 pW/sqrt(Hz) (typ)
Average power reading	Yes	Yes

Model Number	1201 <sup>2</sup>	1201 <sup>2</sup>
Bandwidth	35 GHz (typ), 30 GHz (min)	35 GHz (typ), 30 GHz (min)
Wavelength	800 to 1650 nm	800 to 1650 nm
Number of channels	1	1
Calibrated wavelengths (nm)	850, 1310, 1490, 1550	850, 1310, 1490, 1550
RF coupling	DC	DC
RF connector	2.4 mm	2.4 mm
RF impedance	50 ohms	50 ohms
Fiber	50 $\mu$ core MMF	50 $\mu$ core MMF
Damage level peak power	+8 dBm	+8 dBm
Optical return loss	24 dB SMF1 14 dB MMF	24dB SMF1 14 dB MMF
PDL at 1550 nm	-	-
Conversion gain	100 V/W (typ) at 1550 nm 100 V/W (typ) at 1310 nm 70 V/W (typ) at 850 nm	100 V/W (typ) at 1550 nm 100 V/W (typ) at 1310 nm 70 V/W (typ) at 850 nm
Low frequency cutoff	0 Hz	0 Hz
Noise equivalent power <sup>1</sup>	39.7 pW/sqrt(Hz) (typ)	39.7 pW/sqrt(Hz) (typ)
Average power reading	Yes	Yes

Model Number	1301 <sup>2</sup>	1301 <sup>2</sup>
Bandwidth	50 GHz (typ)	50 GHz (typ)
Wavelength	1200 to 1650 nm	1200 to 1650 nm
Number of channels	1	1
Calibrated wavelengths (nm)	1310, 1490, 1550	1310, 1490, 1550
RF coupling	DC	DC
RF connector	V (1.85 mm)	V (1.85 mm)
RF impedance	50 ohms	50 ohms
Fiber	SMF-28	SMF-28
Damage level peak power	+8 dBm	+8 dBm
Optical return loss	30 dB SMF1	30 dB SMF1
PDL at 1550 nm	0.1 dB (typ), 0.2 dB (max)	0.1 dB (typ), 0.2 dB (max)
Conversion gain	90 V/W (typ) at 1310 nm	90 V/W (typ) at 1310 nm
Low frequency cutoff	0 Hz	0 Hz
Noise equivalent power <sup>1</sup>	41 pW/sqrt(Hz) (typ)	41 pW/sqrt(Hz) (typ)
Average power reading	Yes	Yes

Model Number	1401 <sup>2</sup>	1401 <sup>2</sup>
Bandwidth	9 GHz (typ), 8GHz (min)	9 GHz (typ), 8GHz (min)
Wavelength	750 to 1650 nm	750 to 1650 nm
Number of channels	1 or 2	1 or 2
Calibrated wavelengths (nm)	1271, 1291, 1311, 1331, 1351, 1371, 1391, 1411, 1310, 1490, 1550	1271, 1291, 1311, 1331, 1351, 1371, 1391, 1411, 1310, 1490, 1550
RF coupling	AC	AC
RF connector	SMA	SMA
RF impedance	50 ohms	50 ohms
Fiber	62.5 μ core MMF	62.5 μ core MMF
Damage level peak power	+7 dBm	+7 dBm
Optical return loss	16 dB	16 dB
PDL at 1550 nm	-	-
Conversion gain	10,000 V/W (typ), 7,000 V/W (min) at 1310 nm	10,000 V/W (typ), 7,000 V/W (min) at 1310 nm
Low frequency cutoff	< 100 KHz	< 100 KHz
Noise equivalent power <sup>1</sup>	25.6 nW/sqrt(Hz) (typ)	25.6 nW/sqrt(Hz) (typ)
Average power reading	Yes	Yes



Model Number	1402 <sup>2</sup>	1402 <sup>2</sup>
Bandwidth	9 GHz (typ), 8GHz (min)	9 GHz (typ), 8GHz (min)
Wavelength	750 to 1650 nm	750 to 1650 nm
Number of channels	1 or 2	1 or 2
Calibrated wavelengths (nm)	850, 1310, 1490, 1550	850, 1310, 1490, 1550
RF coupling	AC	AC
RF connector	SMA	SMA
RF impedance	50 ohms	50 ohms
Fiber	62.5 μ core MMF	62.5 μ core MMF
Damage level peak power	+7 dBm	+7 dBm
Optical return loss	16 dB	16 dB
PDL at 1550 nm	-	-
Conversion gain	10,000 V/W (typ), 7,000 V/W (min) at 1310 nm	10,000 V/W (typ), 7,000 V/W (min) at 1310 nm
Low frequency cutoff	< 100 KHz	< 100 KHz
Noise equivalent power <sup>1</sup>	25.6 nW/sqrt(Hz) (typ)	25.6 nW/sqrt(Hz) (typ)
Average power reading	Yes	Yes

Model Number	1403 <sup>2</sup>	1403 <sup>2</sup>
Bandwidth	9 GHz (typ), 8 GHz (min)	9 GHz (typ), 8 GHz (min)
Wavelength	750 to 1650 nm	750 to 1650 nm
Number of channels	1 or 2	1 or 2
Calibrated wavelengths (nm)	1271, 1291, 1311, 1331, 1351, 1371, 1391, 1411, 1310, 1490, 1550	1271, 1291, 1311, 1331, 1351, 1371, 1391, 1411, 1310, 1490, 1550
RF coupling	AC	AC
RF connector	SMA	SMA
RF impedance	50 ohms	50 ohms
Fiber	62.5u MMF	62.5u MMF
Damage level peak power	7 dBm	7 dBm
Optical return loss	16 dB	16 dB
PDL at 1550 nm	-	-
Conversion gain	17,000 V/W (typ), 10,000 V/W (min) at 1310 nm	17,000 V/W (typ), 10,000 V/W (min) at 1310 nm
Low frequency cutoff	<100 kHz	<100 kHz
Noise equivalent power <sup>1</sup>	43 pW/sqrt(Hz) (typ)	43 pW/sqrt(Hz) (typ)
Average power reading	Yes	Yes

#### SPECS AS OF JULY 2022

##### Notes

1. At wavelength with maximum conversion gain.

2. Preliminary specs.

## ORDERING INFORMATION

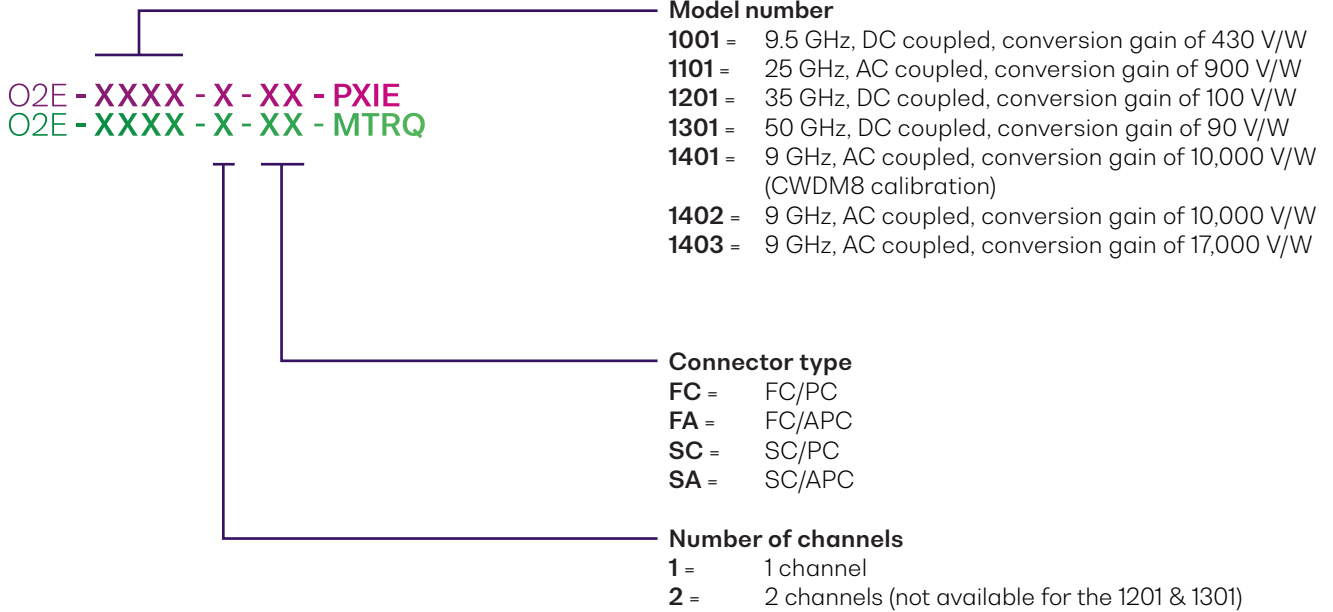

## WARRANTY INFORMATION

This product comes with a standard 1 year warranty.

## EXTENDED WARRANTIES AND CALIBRATION PLANS

With an **extended warranty and calibration plan** you'll spend more time focused on your priorities and less time worrying about maintenance.

Your choice: add a **3 or 5 year extended warranty** when you buy.



### Guarantee performance

Ensure your equipment is operating at the best it can be for reliable and accurate results.

### Lower cost of ownership

Lock in savings and maximise your testing budget with a lower base cost of ownership.

### Peace of mind

Spend less time worrying about maintenance and more on generating results.

## CALIBRATION PLANS FOR ADDITIONAL DISCOUNTS

Order a **calibration plan** when purchasing your Quantifi Photonics instruments and get additional discounts.

### 10% Discount

On calibrations ordered at the time of purchase.

### 25% Discount

Add on an extended warranty and receive a 25% discount on calibrations.

Over time and with regular use, all optical parts and connectors require re-calibration and maintenance to guarantee accurate and reliable performance. We recommend Quantifi Photonics optical instruments are re-calibrated every 12 months. With an instrument calibration performed by Quantifi Photonics technicians you receive:

- Comprehensive calibration to factory specifications
- End-to-end inspection to ensure all instrument functions are working and connectors are clean
- Firmware, software and documentation updates
- Certificate of calibration which includes detailed test results

## How to do I secure my extended warranty or calibration plan?

Contact your Quantifi Photonics sales representative or email [sales@quantifiphotonics.com](mailto:sales@quantifiphotonics.com)

Extended warranties and calibration plans must be ordered at the time of purchase and are available only for Quantifi Photonics' products. The 25% calibration discount only applies to calibrations while the product is covered by the extended warranty period.

Our portfolio of optical & electro-optical test modules is rapidly expanding to meet a wide range of customer requirements and applications.

**Tunable Laser Sources**

Versatile telecom laser sources with full tunability across C or L bands. Narrow 100 kHz linewidth, up to 16.5 dBm of power, optional whisper mode to disable frequency dither.



**Fixed Wavelength Laser Sources**

Highly customizable DFB or FP laser sources available in a wide range of wavelengths and powers. Models support SMF, MMF and PMF.



**Swept, Tunable Continuous Wave Laser**

Swept, tunable continuous wave (CW) laser source with 0.01 dB power stability and 400 nm/s high-speed scan rate for R&D and production testing.



**Superluminescent Diode Broadband Light Source**

Super-luminescent LED light source with high output power, large bandwidth and low spectral ripple and various wavelengths.



**Erbium-Doped Fiber Amplifier (EDFA)**

High power Erbium-Doped Fiber Amplifier for signal power amplification in C and L bands with various control modes, including automatic gain control.



**Variable Optical Attenuator (VOA)**

Fast attenuation speed with low insertion loss and built-in power monitoring. Operates in fixed attenuation or constant output power modes. Models support SMF, MMF and PMF connector types.



**Polarization Controller & Scrambler**

High-speed automated polarization control with broad wavelength coverage from 1260nm to 1650nm, low insertion loss and back reflection. Full remote control via intuitive GUI, LabVIEW or SCPI.



**Optical-to-Electrical Converter**

High bandwidth, broadband O-to-E converter. Available in a range of configurations; choose from 1 or 2 channels, AC or DC coupling and various conversion gain and operating wavelength ranges.



**Optical Switch**

Proven reliability and fast switching time. Wide variety of switch configurations: 1x4, 1x16, 16x16 and more. Models support SMF, MMF and PMF.



**Optical Spectrum Analyzer (OSA)**

Low cost, spectral measurement in a compact module with built-in analysis for: SMSR, OSNR & spectral width. Targeted wavelengths for specific applications in O band, C band & L band.



**Optical Power Meters**

Fast terminating or inline monitoring of optical signal power from -60 to +10 dBm across 750 - 1700 nm wavelengths. Model with logarithmic analog output for applications such as silicon photonics fiber alignment.



**Bit Error Rate Tester (BERT)**

2, 4 or 8-channel Pulse Pattern Generator and Error Detector at rates up to 29 Gbps for the design, characterization and production of optical transceivers and opto-electrical components.



**Photonic Doppler Velocimeter (PDV)**

Purpose-built module for Photonic Doppler Velocimetry (PDV). A circulator, two VOAs and a passive coupler all built into one compact module.



**Passive Component Integration**

Integrate passive optical components of your choice such as WDM couplers, splitters, band-pass filters, PM beamsplitters and circulators. Models support SMF, MMF and PMF.



**Passive Component Storage**

Protect and store your own passive fiber optic components such as splitters, connector adaptor patchcords, WDM couplers, and isolators in one handy module.



PXI - MODULAR SYSTEM

MATRIQ - COMPACT BENCHTOP

See our website for more details  
[quantifotonics.com/products](http://quantifotonics.com/products)

# Test. Measure. Solve.<sup>TM</sup>

Quantifi Photonics is transforming the world of photonics test and measurement. Our portfolio of optical and electrical test instruments is rapidly expanding to meet the needs of engineers and scientists around the globe. From enabling ground-breaking experiments to driving highly efficient production testing, you'll find us working with customers to solve complex problems with experience and innovation.

**To find out more, get in touch with us today.**

<b>General Enquiries</b>	<a href="mailto:sales@quantifiphotonics.com">sales@quantifiphotonics.com</a>
<b>Technical Support</b>	<a href="mailto:support@quantifiphotonics.com">support@quantifiphotonics.com</a>
<b>Phone - NZ</b>	+64 9 478 4849
<b>Phone - USA</b>	+1-800-803-8872

[quantifiphotonics.com](https://www.quantifiphotonics.com)

**QUANTIFI  
PHOTONICS®**